

---

# **PROCEDURES FOR IMPLEMENTATION OF REC MECHANISM**

---

# INDEX

---

- **MODEL GUIDELINES FOR ACCREDITATION BY STATE AGENCY**
- **REGISTRATION BY CENTRAL AGENCY**
- **ISSUANCE OF REC<sub>s</sub> BY CENTRAL AGENCY**
- **REDEMPTION OF REC<sub>s</sub>**

---

# Schematic for REC Implementation Procedures

---

# Model Guidelines / Procedure for Accreditation

---

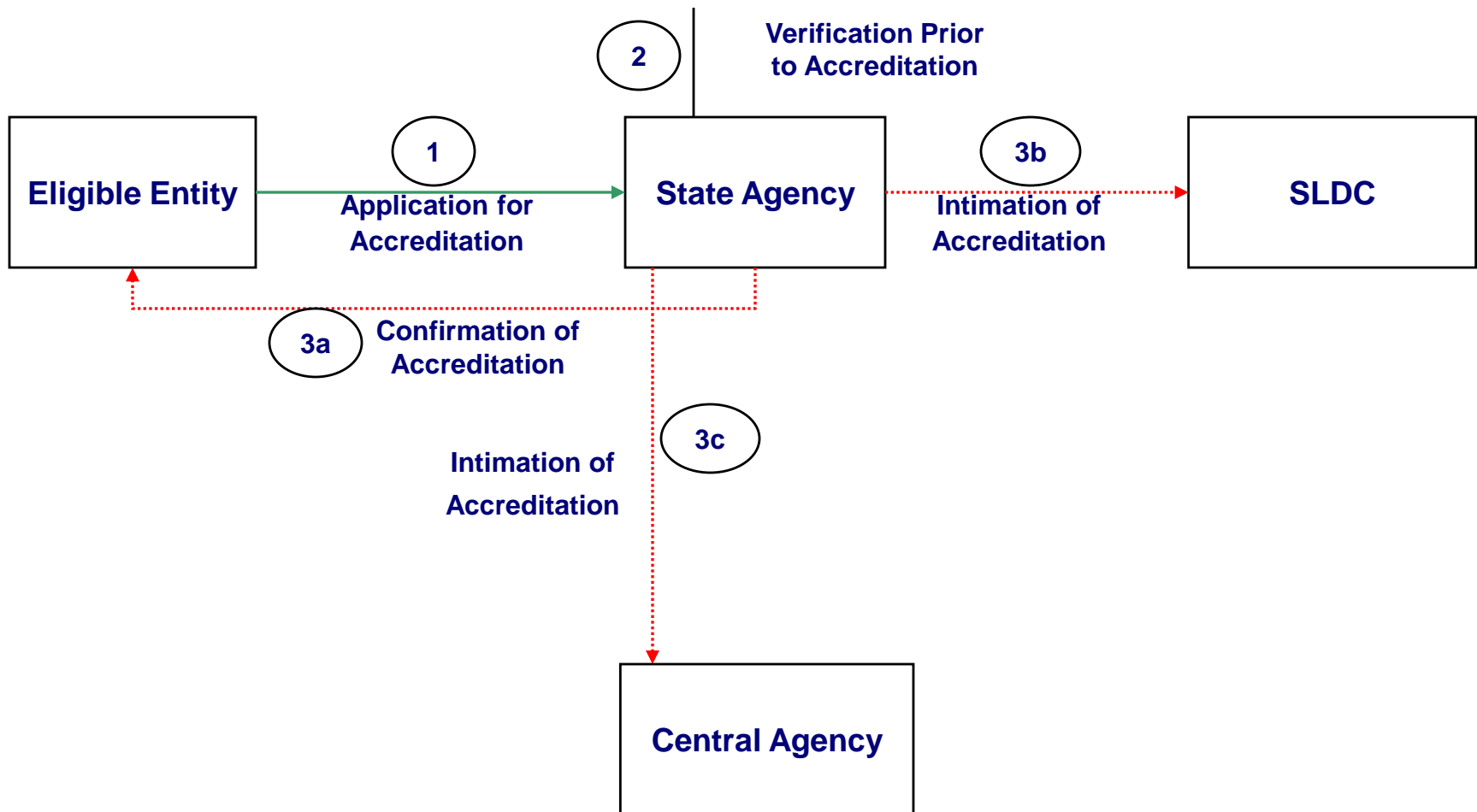

# Procedure for Registration

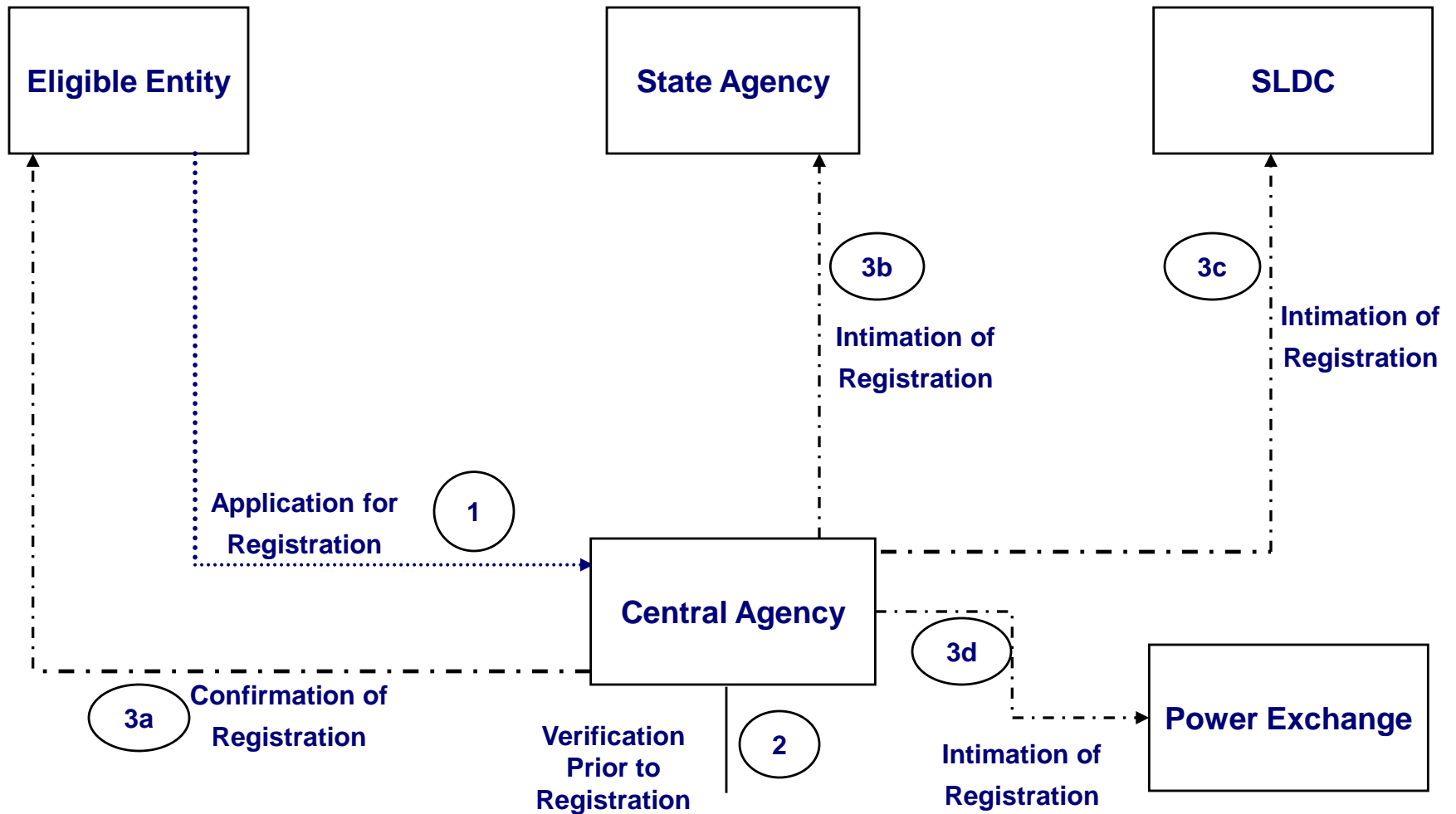

# Procedure for Issuance

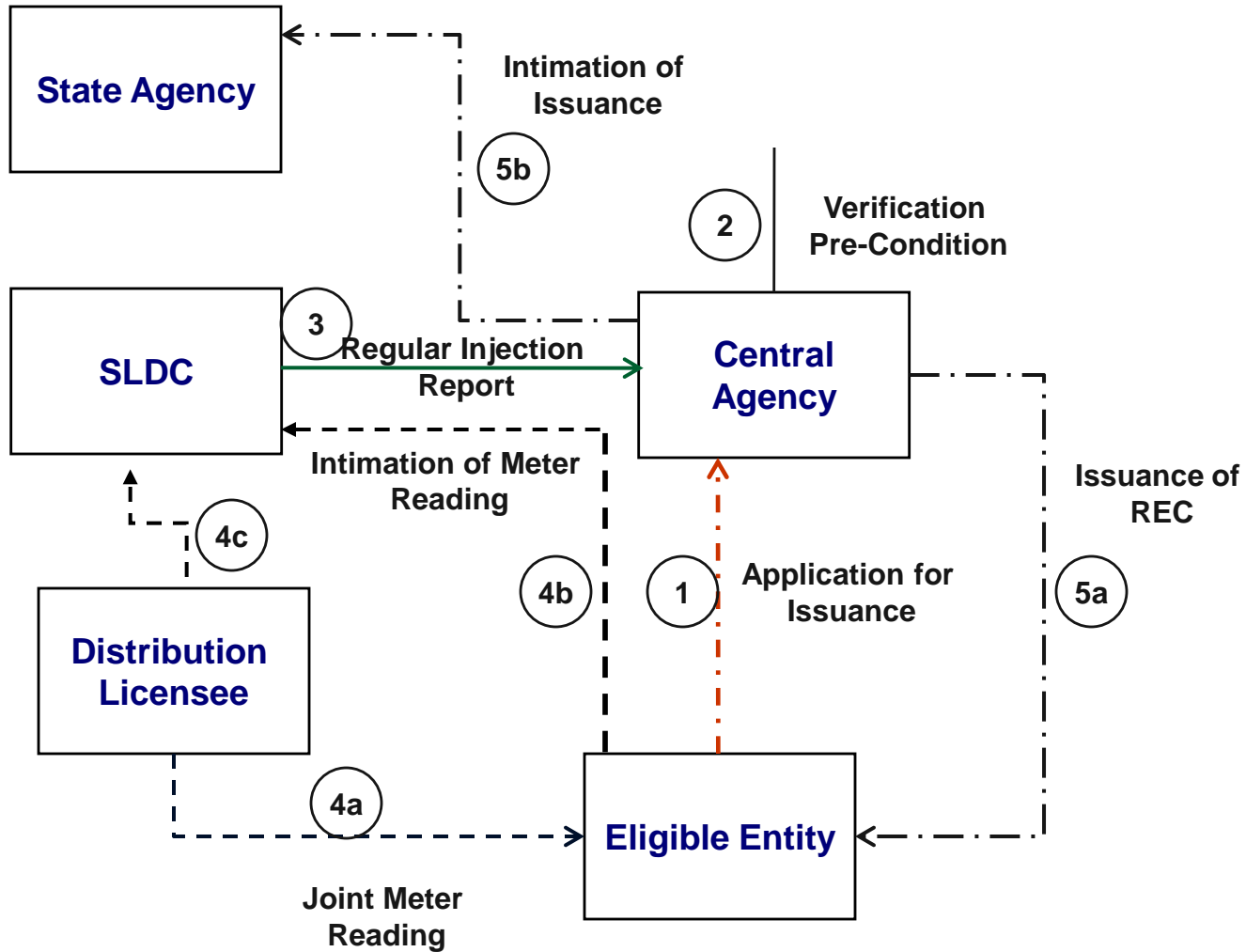

# Procedure for Redemption

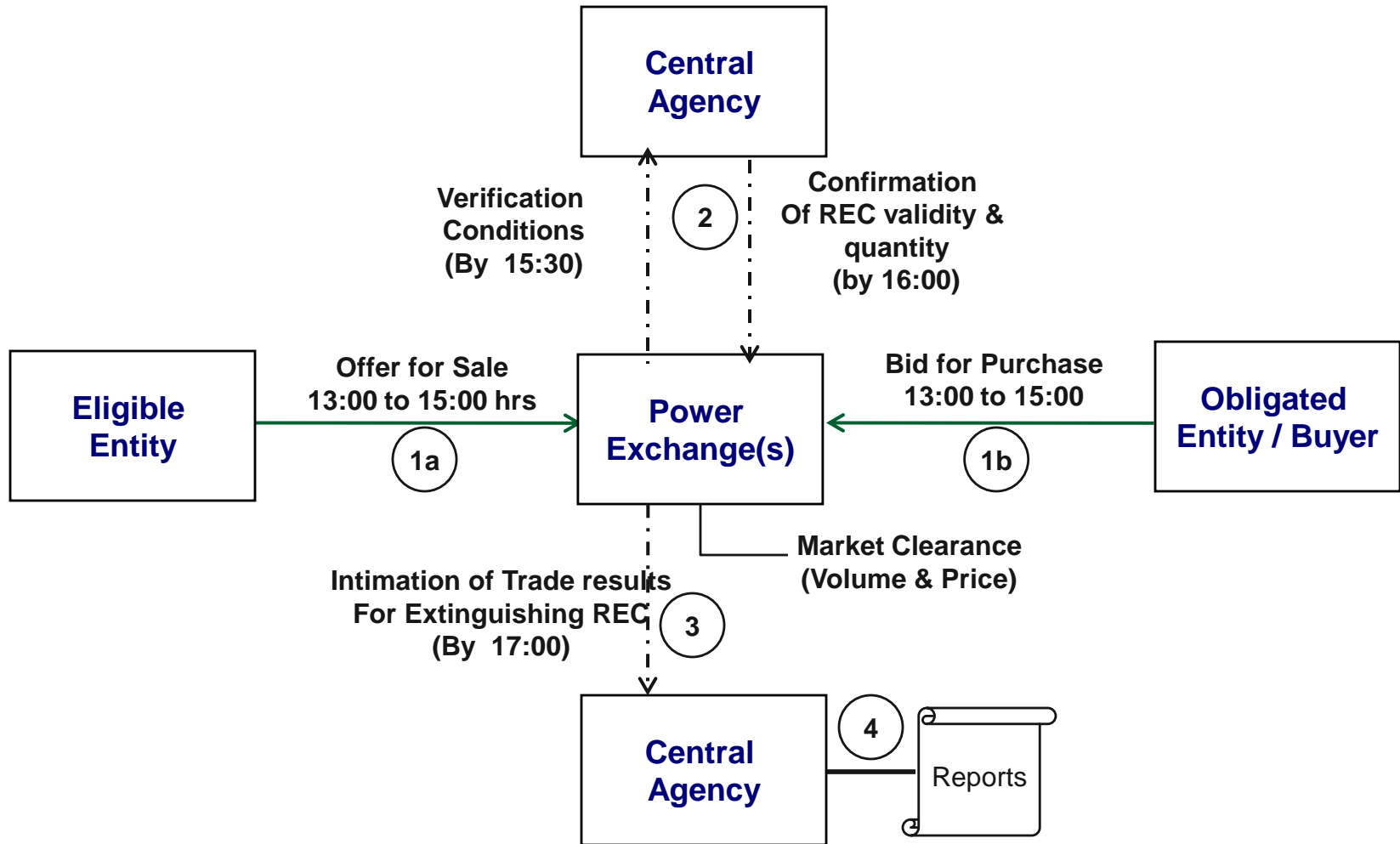

---

# **MODEL GUIDELINES FOR ACCREDITATION BY STATE AGENCY**

# Model Guidelines: Contents

---

- **Objective**
- **Applicability & Scope**
- **Step wise description**
- **Functions, roles and responsibilities of entities involved**
- **Information requirement – application form & content**
- **Report: format for accreditation certificate**
- **Timelines**
- **Fees and charges**
- **Event of default and consequences thereof**
- **Powers to remove difficulties**

# Model Guidelines: Applicability & Scope

---

- **Applicable to all Generating Companies Using RE sources for generation as recommended by MNRE.**
- **State Commission to designate State Agency to recommend the accreditation of RE Generators.**
- **State Agency to undertake accreditation six months earlier than from commissioning date.**
- **Validity of accreditation: 5 years**

# Model Guidelines: Information Requirement

---

- **Owner**
- **Operator**
- **RE Station**
- **Connectivity**
- **Metering**
- **Statutory Clearance**
- **General**
- **Fees & Charges**
- **Declaration**

*Online generation of Application, print & submit to State Agency along with enclosures*

# Model Guidelines: Timelines, Fees & Charges

---

## ■ **Timelines:**

- ❑ Undertake accreditation of those generating facilities which are proposed to be commissioned within period not exceeding 6 months from the date of application.
- ❑ State Agency to inform the applicant with regard to the incompleteness of the application within 2 working days.
  - Applicant to respond within 7 working days.

## ■ **Fees & Charges for State Agency**

- ❑ One time application processing fees
- ❑ One time accreditation charges
- ❑ Annual charge for accreditation
- ❑ Accreditation charges for re-validation/extension

---

# REGISTRATION BY CENTRAL AGENCY

# Registration: Applicability and Scope

---

- **Applicable to all RE Generating companies who have received the Certificate of accreditation**
  
- **Undertake registration**
  - Not earlier than 3 months prior to proposed date of commissioning
  - After receipt of Certificate of Accreditation
  
- **Validity of Registration: 5 Years**

# Registration: Information Requirement

---

- **Application for Registration as per the format specified**
- **Should contain**
  - Owner details
  - RE Generation Station details
  - Certificate of Accreditation by the state agency
  - Generation facility commissioning schedule
  - Any other relevant information as specified
  - Non-refundable registration fees/charges and annual fee/charges shall be accompanied
  - Declaration
- **Separate applications in case of multiple RE generation projects**

***Online generation of Application, print & submit to Central Agency along with enclosures***

---

# Registration: Time Line

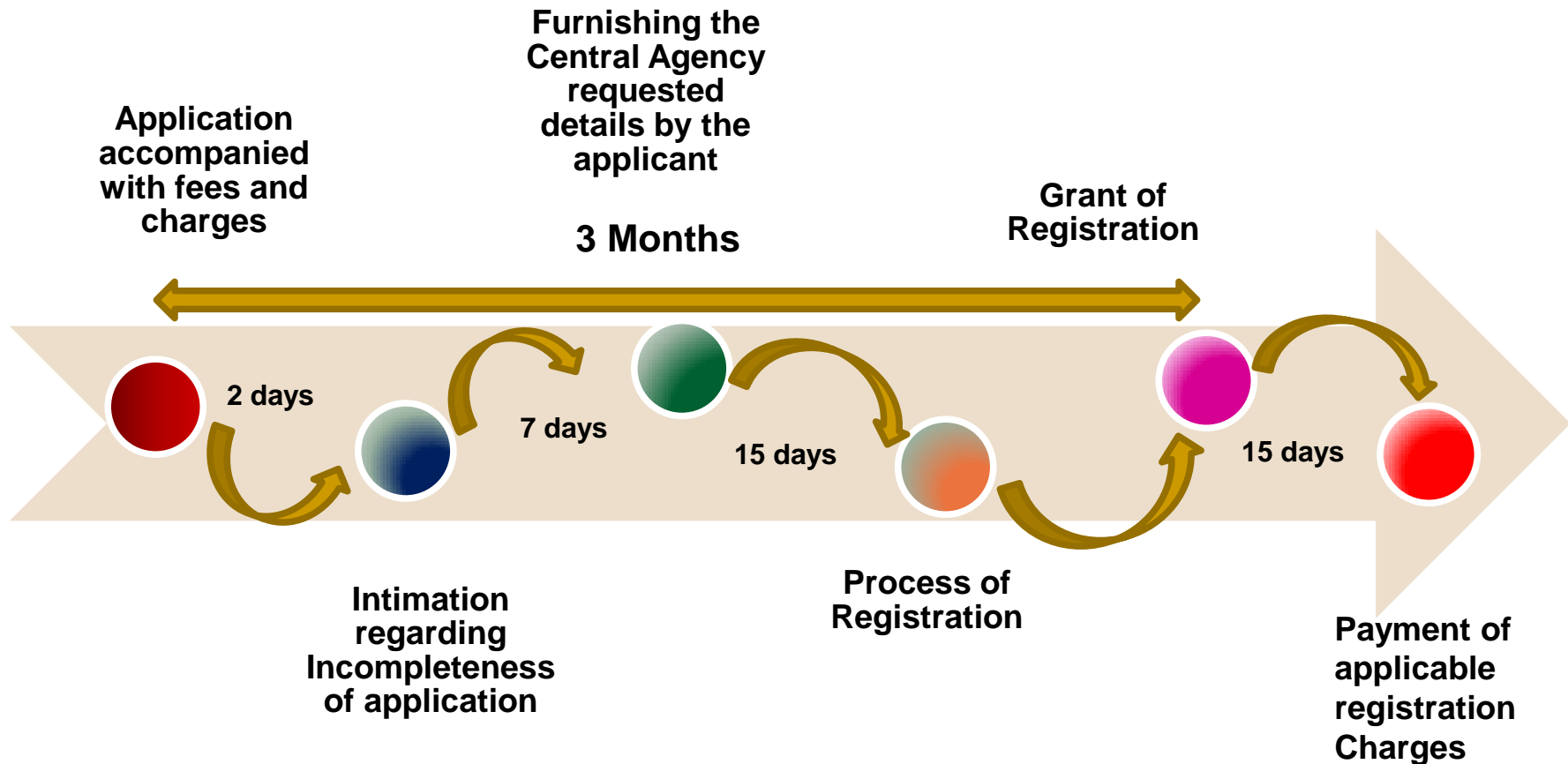

# Registration: Fees and Charges

---

- **One time Registration processing fees**
- **One time registration Charges**
- **Annual charges for Registration**
- **Registration Charges for Revalidation/ extension of validity**

---

# ISSUANCE OF REC<sub>s</sub> BY CENTRAL AGENCY

---

# Issuance of RECs

---

## ■ **Applicability & Scope**

- ❑ Eligible Entities, who have received 'Certificate of Registration' from the Central Agency
- ❑ Central Agency while issuing the REC'S to Eligible Entities

## ■ **Information Requirement**

- ❑ Renewable Energy Injection Report
- ❑ The Registration Number issued by Central Agency
- ❑ Details of Fee and Charges
- ❑ Compliance Auditor report, if any

## ■ **Denomination**

- ❑ 1 REC = 1 MWh

# Issuance of RECs: Timelines

---

- **Eligible Entity to apply for issuance of renewable energy certificates within three (3) months of energy injection**
- **The application for issuance of Renewable Energy Certificates may be made on a fortnightly basis**
- **Central Agency to issue the REC to the Eligible Entities within fifteen (15) days from the date of application**

---

# REDEMPTION OF REC<sub>s</sub> AFTER TRADE IN POWER EXCHANGE(s)

---

# Redemption of RECs

---

- **Validity of RE Certificates : 365 days**
- **Applicable to the Eligible Entity that chooses to place the RECs for dealing on the Power Exchange(s)**
- **Bidding in the Power Exchange(s)**
- **Central Agency to verify quantity of valid RECs available with the concerned eligible entity**
- **Extinguishing of the RECs based on the successful trades culminated in the Power Exchange(s)**
  - **First-in-first-out order for extinguishing**

# Draft Procedures for REC Implementation

---

## ■ Available for stakeholder comments on:

□ [www.forumofregulators.org](http://www.forumofregulators.org)

□ [www.cercind.gov.in](http://www.cercind.gov.in)

□ [www.nldc.in](http://www.nldc.in) / [www.nldcindia.in](http://www.nldcindia.in)

□ [www.forumofloaddespatchers.in](http://www.forumofloaddespatchers.in) / [www.forumofd.in](http://www.forumofd.in)

---

**Thank you !!**

---

**Email ID:**

**[reccentralagency@powergridindia.com](mailto:reccentralagency@powergridindia.com)**